

The 220-ohm resistors are combined by 4 in an 8-pin SIL footprint  
 e.g. Bourns 4608X-102-221  
 or BI Technologies L83C221

Display board

Audio Relay & Power board

|  |                                   |                              |
|--|-----------------------------------|------------------------------|
| Title                                    |                                   |                              |
| <b>Balanced preamp - Digital control</b> |                                   |                              |
| Size                                     | Number                            | Revision                     |
| A4                                       | Copyright Jos van Eijndhoven      | 1.0                          |
| Date:                                    | 29-3-2008                         | Sheet of                     |
| File:                                    | E:\DOCUMENTS\JOS\SheetDisplay.Sch | Drawn By: Jos van Eijndhoven |

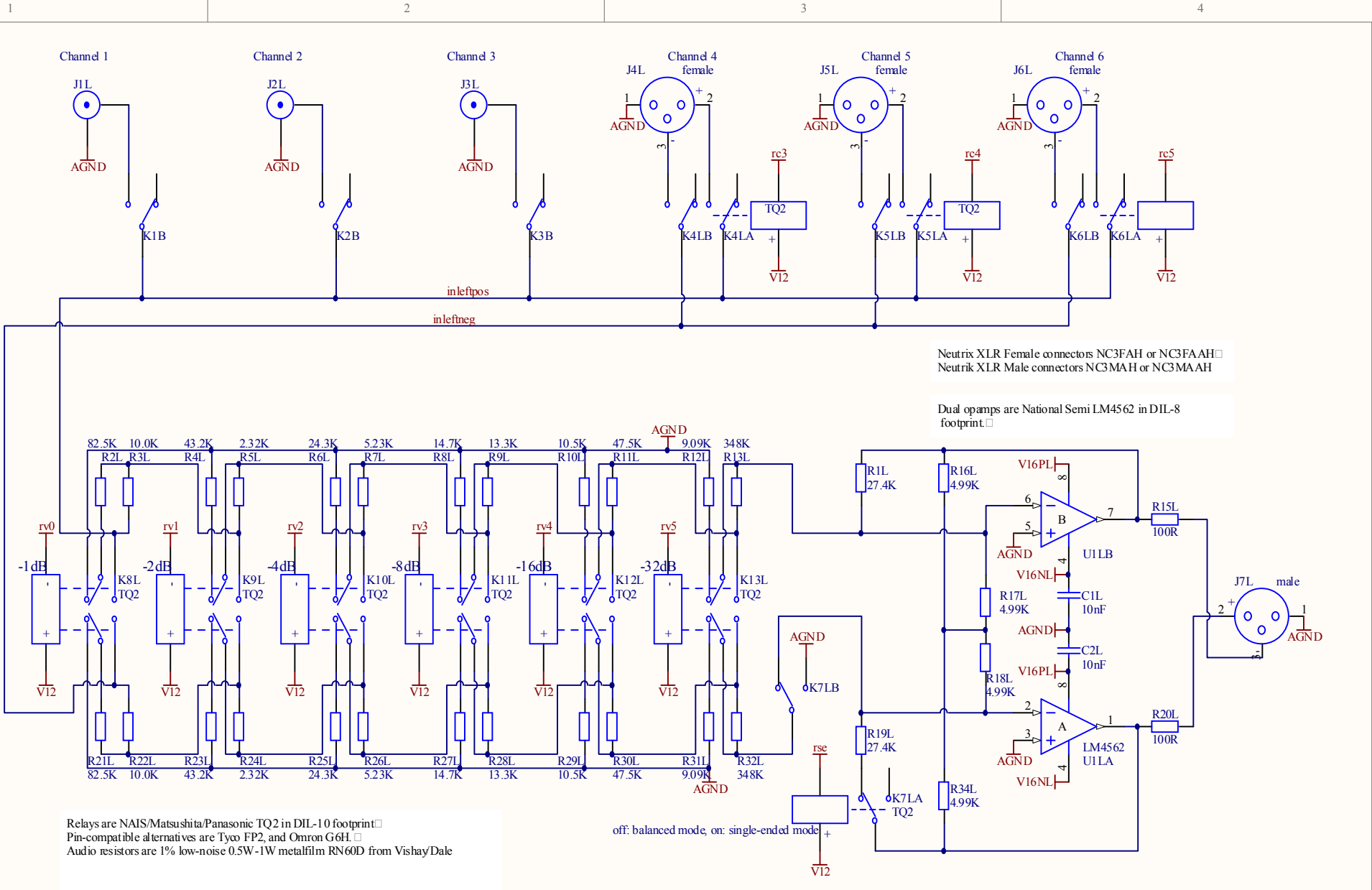

Neutrix XLR Female connectors NC3FAH or NC3FAAH □  
 Neutrik XLR Male connectors NC3MAH or NC3MAAH

Dual opamps are National Semi LM4562 in DIL-8 footprint □

Relays are NAIS/Matsushita/Panasonic TQ2 in DIL-10 footprint □  
 Pin-compatible alternatives are Tyco FP2, and Omron G6H. □  
 Audio resistors are 1% low-noise 0.5W-1W metalfilm RN60D from Vishay/Dale

off: balanced mode, on: single-ended mode +

|                                     |  |          |
|-------------------------------------|--|----------|
| Title                               |  |          |
| <b>Balanced preamp - Left Audio</b> |  |          |
| Size                                | Number   | Revision |
| A4                                  |  | 1.1      |
| Copyright Jos van Eijndhoven        |  |          |
| Date:                               | 4-3-2008   | Sheet of |
| File:                               | E:\DOCUMENTS\JOS\SheetRelaysLeftSchematicBy: jos@vaneijndhoven.net |          |

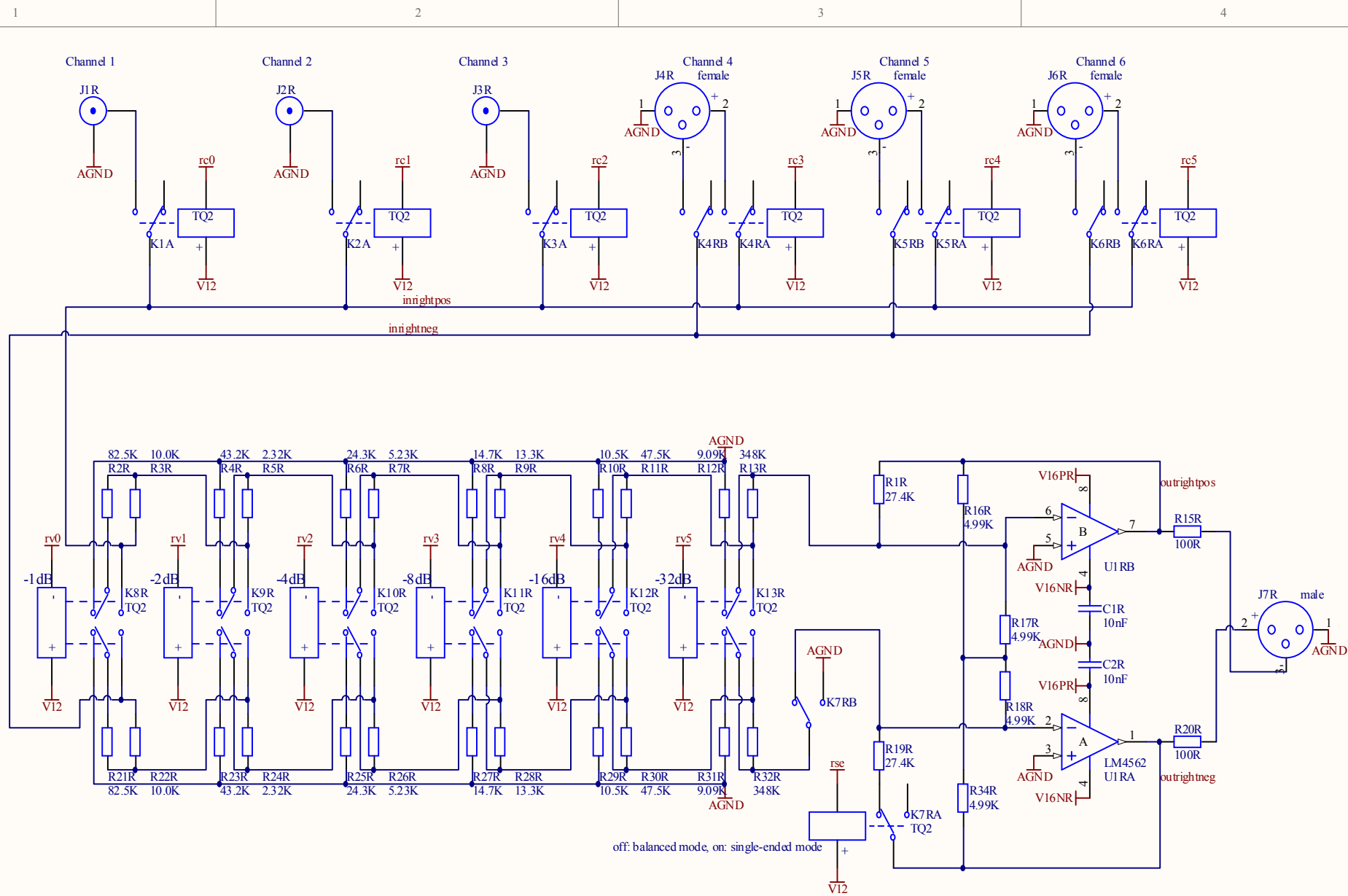

|                               |   |                                 |
|-------------------------------|---|---------------------------------|
| Title                         |   |                                 |
| Balanced preamp - Right Audio |   |                                 |
| Size                          | Number                                    | Revision                        |
| A4                            |   | 1.1                             |
| Copyright Jos van Eijndhoven  |   |                                 |
| Date:                         | 4-3-2008                                  | Sheet of                        |
| File:                         | E:\DOCUMENTS\JOS\Sheet Relays Right Audio | Drawn By: jos@vaneijndhoven.net |

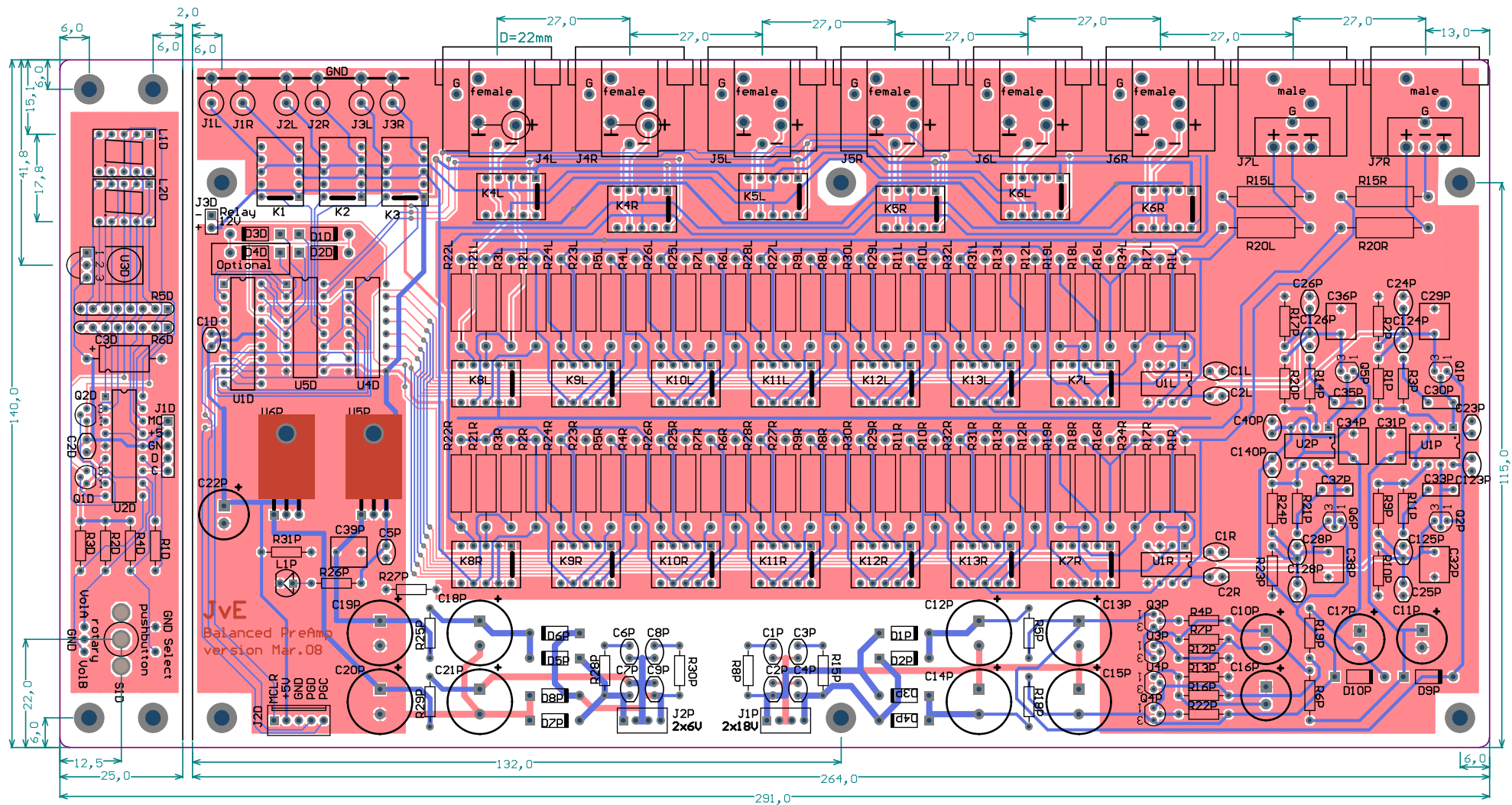

Dimensions in mm  
Print-out scaled to 85%